

Whirl Wind Propellers

1800-C Joe Crosson Drive, El Cajon, CA 92020
619-562-3725

SERVICE LETTER

SL-GA-J2B-012714

TO: ALL OWNERS / OPERATORS OF AFFECTED PROPELLERS
SUBJECT: BLADE CLAMP BOLT CRACK
DATE: JANUARY 27, 2014

MODELS AFFECTED: All WhirlWind **GA-J2B** propellers with hubs in the Serial Number range **1000 to 1107** installed on UL-350i engines.

REASON: Upon routine inspection of a **GA-J2B** propeller in the affected Serial Number range, installed on a UL350i engine, one of the propeller blade clamp bolts (AN5-15A) was found to have a crack. The propeller was installed on a UL-350i engine, with 65" diameter blades. The propeller had 300+ hours total time. The bolt crack found so far has been an isolated case.

The **GA-J2B** propeller design went into service in February 2009, and has been installed primarily on Jabiru 3300 and UL350i engines (as well as other engines) for the last 4 years with no bolt cracking issues.

ACTION: *Reference Figure 1 on Page 2*

Recommend replacement of all 6 hub clamp bolts (AN5-14A for UL350i installations) at time of every annual or every 100 hrs, whichever occurs first.

Affected propellers older than 1 year or with more than 100 hrs: Mandatory replacement of all 6 hub clamp bolts (AN5-14A for UL350i installations) before next flight.

Optional: Owners of affected propellers may trade-in affected propeller hub and purchase new style UL350 hub (See Figure 2) at reduced cost. Contact WhirlWind Propellers directly for pricing.

FIGURE 1 (SL-GA-J2B-012714)

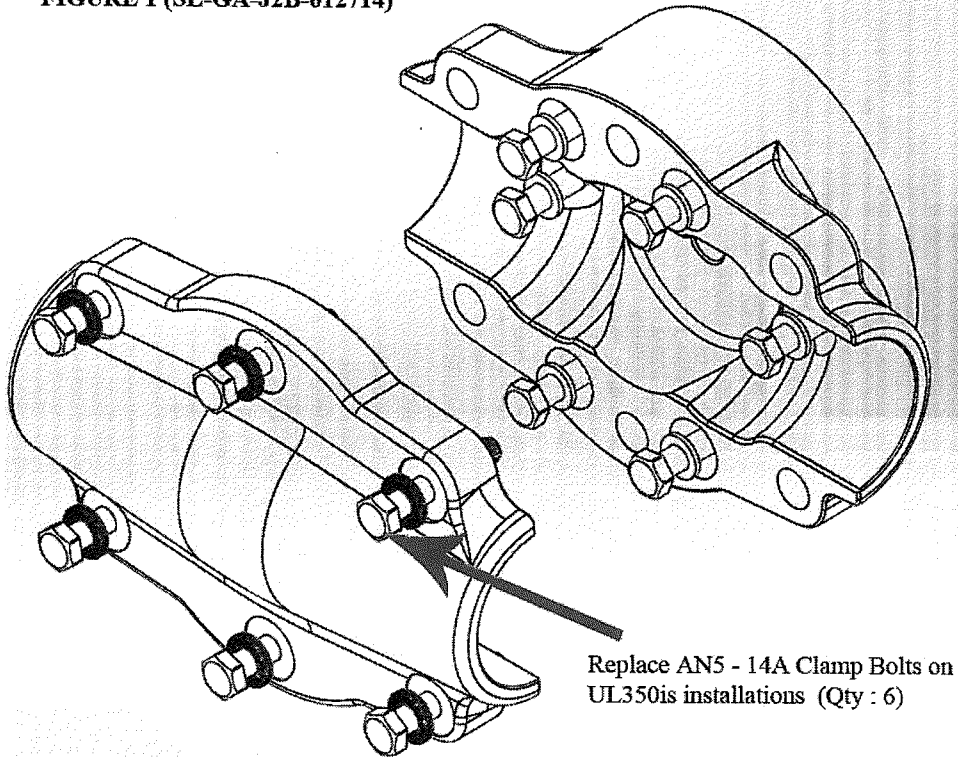

FIGURE 2 (SL-GA-J2B-012714)

New GAJ2B Hub Design UL350

